



TWO POST CAR LIFTING OPERATING MANUAL

Model: QJY4.5-D



CONTENTS

1	Safety	3
1.1	Introduction	3
1.2	Symbols.....	3
1.3	Intended Use	3
1.4	Safety Instructions for Commissioning.....	3
1.5	Safety Instructions for Operation	4
1.6	Safety Instructions for Servicing	4
1.7	Safety Features	4
1.7.1	Operation in the proper position.....	4
1.7.2	Equalizing System	4
1.7.3	Collision Prevention Switch	4
1.7.4	Pinch Point Protection	4
1.7.5	Automatic Arm Restraint.....	5
1.7.6	Pipe Break Valve	5
1.7.7	Pressure Relief Valve	5
2	Specifications	5
3	Operation	6
3.1	Defects / Malfunctions.....	7
3.2	Controls.....	7
3.2.1	Control Unit.....	7
3.2.2	Arm Restraint.....	8
3.3	Operation.....	8
3.3.1	Preparations	8
3.3.2	Raising.....	9
3.3.3	Vehicle in Raised Position	9
3.3.4	Lowering	9
3.4	Manual Lowering.....	10
4	Maintenance	10
4.1	Maintenance Schedule.....	10
4.2	Annual Inspection.....	11
4.3	Maintenance by the Operator	11
4.3.1	Hydraulic System	11
4.3.2	Greasing Points	11
4.3.3	Operational and Wear Checks	12
4.3.4	Lift Stability	12
4.4	Cleaning	12
4.5	Troubleshooting	12
4.6	Disposal	12
4.7	Installation	14
5	Hydraulic drawing	17
6	Exploded drawing	18

1 Safety

1.1 Introduction

Thoroughly read this manual before operating the lift and comply with the instructions. Always display the manual in a conspicuous location.

Personal injury and property damage incurred due to non-compliance with these safety instructions are not covered by the product liability regulations.

1.2 Symbols



Failure to comply with instructions could result in personal injury.



Failure to comply with instructions could result in property damage.



Important information.

1.3 Intended Use

The lift is designed for the safe lifting of automotive vehicles. Observe the rated load capacity and load distribution of the lift.

Model	Load Capacity	Load Distribution Front : Rear	
		Minimum	Maximum
QJY4.0-D	4000kg	2 : 3	3 : 2

In principle, the lift is designed for both approach directions. For a long service life, we recommend to use short support arms for engaging the engine side of the vehicle.

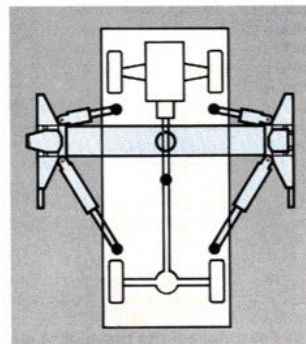

1.4 Safety Instructions for Commissioning

- Ⓢ The lift may be installed and commissioned by authorized service personnel only.
- Ⓢ The standard lift version may not be installed and commissioned in the vicinity of explosives or flammable liquids, outdoors or in moist rooms (e.g. car wash).

1.5 Safety Instructions for Operation

Read the operating manual.
Lift operation by authorized personnel over 18 years only.
Always keep the lift and lift area clean and free of tools, parts, debris etc.
Once the disk adapters contact the lift points, please check arm restraints for engagement.
After raising the vehicle briefly, stop and check the disk adapters for secure contact.
Always lift the vehicle using all four adapters.
Make sure the vehicle doors are closed during raising and lowering cycles.
Closely watch the vehicle and the lift during raising and lowering cycles.
Do not allow anyone to stay in lift area during raising and lowering cycles.
Do not allow anyone on lift or inside raised vehicle.
Only use the lift for its intended usage.
Comply with the applicable accident prevention regulations.
Do not overload the lift. The rated load capacity is indicated on the lift nameplate.
Only use the vehicle manufacturer's recommended lift points.
After positioning the vehicle apply the parking brake.
Use caution when removing or installing heavy components (center-of-gravity displacement).
Keep all parts of the electrical equipment away from humidity and moisture.

1.6 Safety Instructions for Servicing

- ⑩ Maintenance or repair work by authorized service personnel only.
- ⑩ Work on pulse generators or proximity switches by authorized service personnel only.
- ⑩ Work on the electrical equipment by certified electricians only.
- ⑩ Ensure that ecologically harmful substances are disposed of in accordance with the appropriate regulations.
- ⑩ Do not use high pressure / steam jet cleaners or caustic cleaning agents. Risk of damage!
- ⑩ Do not replace or override the safety devices.

1.7 Safety Features

1.7.1 Operation in the proper position

The operator is required to hold the controls in the proper position to raise or lower the lift.

1.7.2 Equalizing System

The lift is provided with equalizing cables to ensure level movement of both carriages.

1.7.3 Collision Prevention Switch

A limit switch prevents collisions between cylinder top end and its slide block.

1.7.4 Pinch Point Protection

During descending the support arms lower down by hold to run, safety bar provided for pinch protection.

1.7.5 Automatic Arm Restraint

	QJY4.0-D
Height overall	2832mm
Full travel	>1630mm
Raising / Lowering time	Approx. 50s
Lifting height max.	1910mm
Lifting height min.	95mm
Support arm reach	717... 1070mm 900... 1380mm
Inside columns	2763mm
Drive-through clearance max.	2483mm
Load capacity	4000kg
Net weight	543kg
Anchoring	M19*140
Concrete grade min.	C20/25(DIN 1045:2001-07)
Motor power	2.2kW
Rated current	14.6A
Fuse protection	16 A time delay
Power supply	220V/380V 50HZ
Sound pressure level	≤75dB(A)
Hydraulic pressure	20MPa

1.7.6 Pipe Break Valve

The hydraulic cylinders are equipped with pipe break valves. They respond in case of rapid pressure drop (line break) to prevent sudden lowering movements.

1.7.7 Pressure Relief Valve

A pressure relief valve is used to limit the hydraulic working pressure to a maximum of 150 bars.

2 Specifications

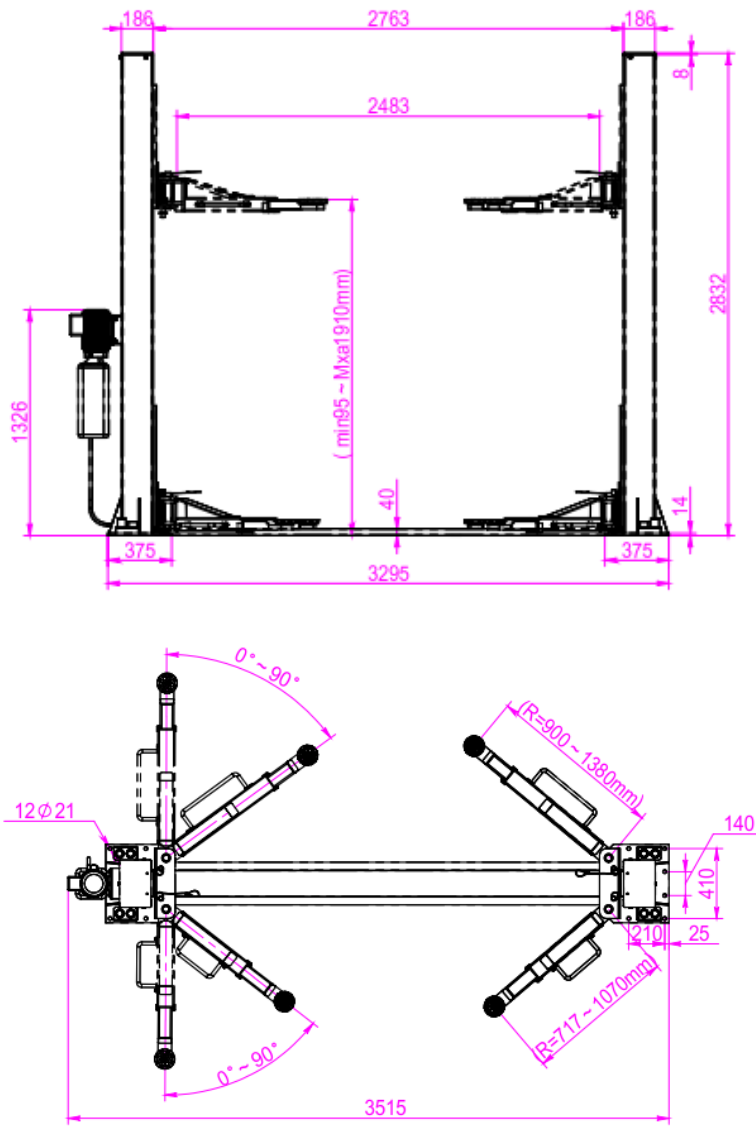

3 Operation



Lift operation by authorized personnel over 18 years only.
 Apply the parking brake after positioning the vehicle on the lift.
 Do not allow anyone to stay in lift area during raising and lowering.
 Closely watch the vehicle and the lift during raising and lowering.

Observe the rated load capacity and load distribution.

Do not allow anyone to climb on lift or stay inside vehicle.

After raising the vehicle briefly, stop and check adapters for secure contact.

Once the disk adapters contact the lift points, check arm restraints for engagement. Make sure the vehicle doors are closed during raising and lowering.

3.1 Defects / Malfunctions



In case of defects or malfunctions such as jerky lift movement or deformation of the superstructure, support or descend the lift immediately. Pull out the power plug. Contact with qualified service personnel.

3.2 Controls

3.2.1 Control Unit

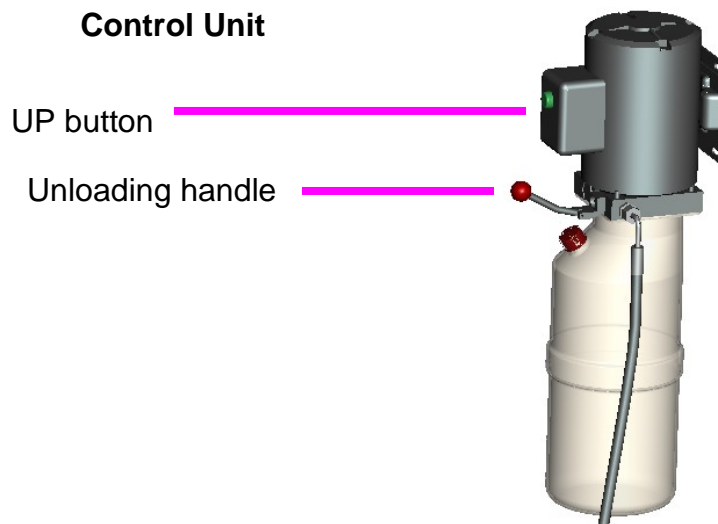

Once any button is actuated, press the Green button, the lift moves until the button is released. When the Green button is released, press the Unloading Handle once to set the lift on the mechanical locks automatically.

Press the Up button once first, insure the safety plate is in disengaged position, press the Unloading Handle to lower the lift

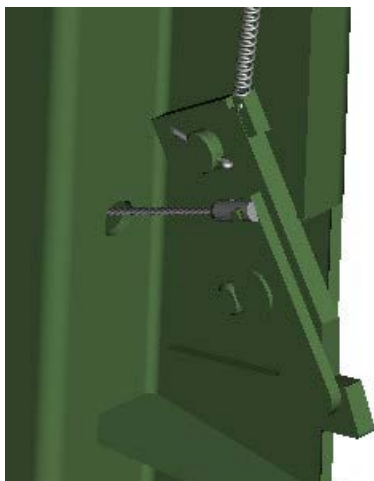

Disengaged Position

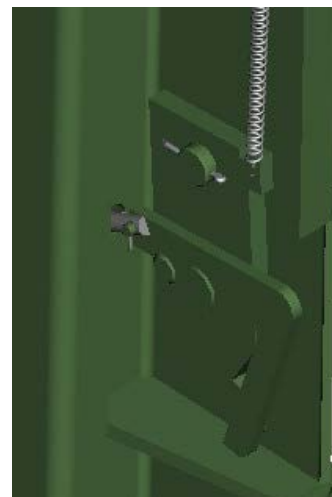

Engaged Position

3.2.2 Arm Restraint



Once the disk adapters contact the lift points, please check arm restraints for engagement.
If necessary, slightly move the arms until the gear segments mesh. Never unlatch the arm restraints when the lift is under load.

Each support arm is provided with an automatic arm restraint which unlatches automatically when the lift is in bottom position.

When carriages are in a raised position, the arm restraint can be disengaged by pulling the Pull Handle

Pull Handle

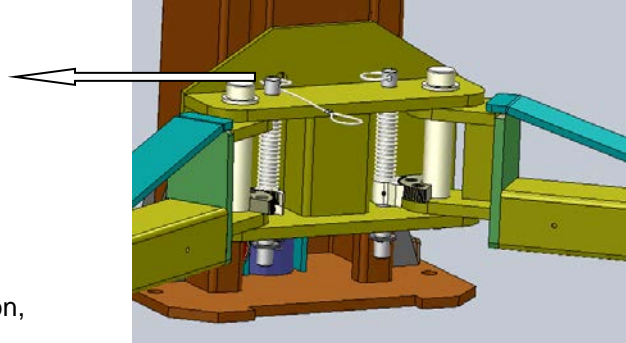

3.3 Operation

3.3.1 Preparations

- 1 Fully lower the lift and swing the arms to full drive-through position.
- 2 Slowly position vehicle midway between adapters. Apply the parking brake.
- 3 Swing and telescope arms as required to position adapters under vehicle at manufacturer's recommended lift points.
- 4 Turn the disk adapters that they evenly contact all four lift points.
- 5 Leave vehicle and remain clear of lift.

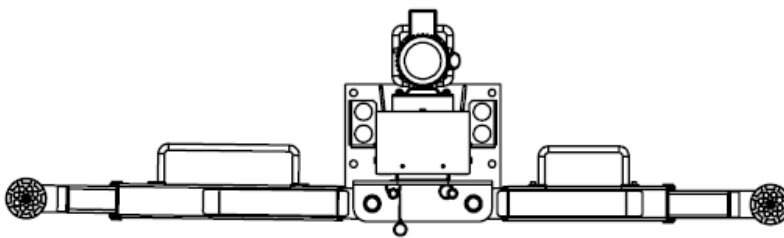

Drive-through position



Always lift the vehicle using all four adapters.

3.3.2 Raising



During lift's raising and lowering: Closely watch the vehicle and the lift, do not allow anyone to stay in lift area and make sure the vehicle doors are closed.

Once the disk adapters contact the lift points, please check arm restraints for engagement. After raising the vehicle briefly, stop and check adapters for secure contact.

- 1 Plug in the power plug
Lift is ready for operation.
- 2 Push and hold GREEN button until lift reaches desired height.
Lift stops once button is released.



3.3.3 Vehicle in Raised Position

- ⓐ Observe all accident prevention regulations.
- ⓐ Do not allow unauthorized persons to stay under the raised vehicle.
- ⓐ Avoid rocking of vehicle.
- ⓐ Keep lift free of tools, parts, etc.
- ⓐ Fasten the vehicle to the support arms using lashing straps when removing or installing heavy components.

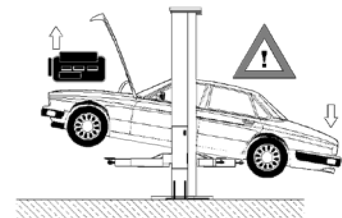

Set on Locks

Use the Unloading Handle to set the lift on the mechanical locks. In this way the vehicle can be securely fixed when the vehicle is in a raised position.

3.3.4 Lowering



During raising and lowering cycles: Closely watch the vehicle and the lift, do not allow anyone to stay in lift area and make sure the vehicle doors are closed.

- 1 Remove tools, stands or other objects from lift bay.
- 2 If the safety plate is in the engaged position, briefly raise the lift before lowering.
- 3 Pull the unlocking steel wire at both columns.
- 4 Press the Unloading Handle until lift reaches desired height.
Lift stops once Relief Handle is released or downward travel limit is reached. During lowering cycles the support arms automatically stop at a height of 110mm above bottom position.
- 5 To lower the arms completely, push the Unloading Handle
- 6 Swing arms to full drive-through position and drive the vehicle off the lift.

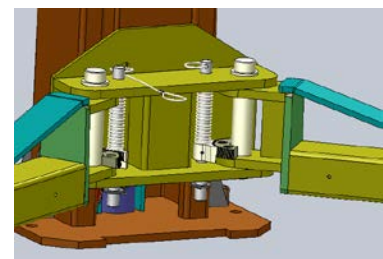

3.4 Manual Lowering

In case of motor defect or power failure the lift can be lowered manually.



Authorized personnel only! Do not restart the lift before the error has been remedied.



If the lift load lies fully on the safety plates, manual lowering is not possible.

Safety Plate in engaged position

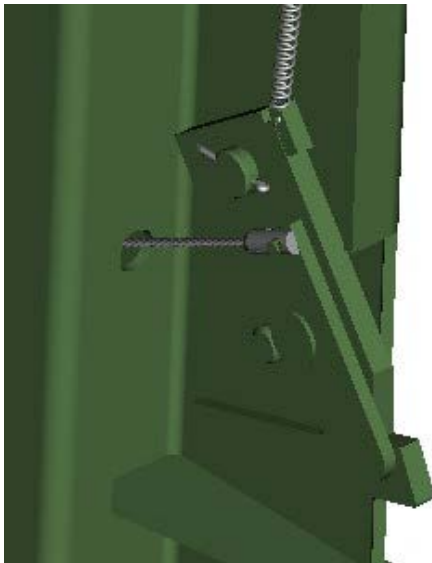

Safety Plate in disengaged position

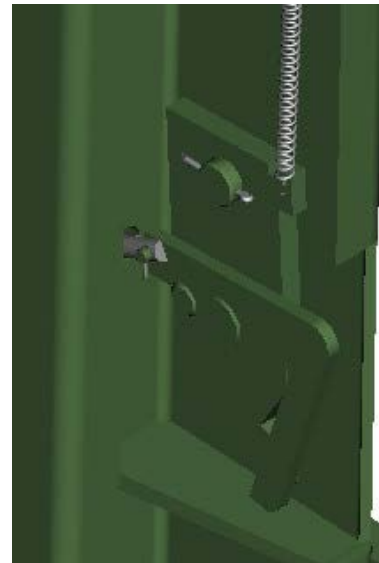

4 Maintenance



Pull the plug before servicing the lift.



The maintenance intervals indicated below apply to average workshop use. The lift should be inspected more frequently for severe use applications.

4.1 Maintenance Schedule

Establish a periodic preventive maintenance procedure to ensure trouble free operation and long service life.

Interval	Maintenance to be performed on	Items
----------	--------------------------------	-------

1 week	Support arms / Disk adapters	ⓐ Check rubber pads for wear. ⓐ Check arm restraints for engagement.
	Greasing points	ⓐ Check and lubricate as required: - Slide tracks - Arm extensions - Threads of disk adapters
6 months	Nuts of anchor bolts	ⓐ Check all nuts for correct torque and retighten them as required.
	Hydraulic system	ⓐ Check fluid level. ⓐ Check tightness of hoses and fittings.
12 months		

4.2 Annual Inspection

We recommend the lift inspected by qualified service personnel every 12 months.

4.3 Maintenance by the Operator

4.3.1 Hydraulic System

- 1 Once a year check the fluid level (see below) with the lift fully lowered and add fluid as required.
- 2 Visually check all hydraulic hoses for tightness.



The hydraulic fluid must be replaced periodically depending on aging, soiling and water absorption. It is recommended to replace the pressure hoses as required, but after six years at the latest.

Checking the Fluid Level

The fluid level can be read through the transparent reservoir at the power unit. With the lift fully lowered, the fluid level must reach above the min level.

4.3.2 Greasing Points

Slide Tracks



The slide tracks inside the columns should be greased every six months (or more frequently in case of noise generation).

1. Slightly grease the slide tracks over their whole length using a brush.

4.3.2.1 Arm Extensions

1. Every six months check the support arm extensions for smooth operation.
2. Grease as required.

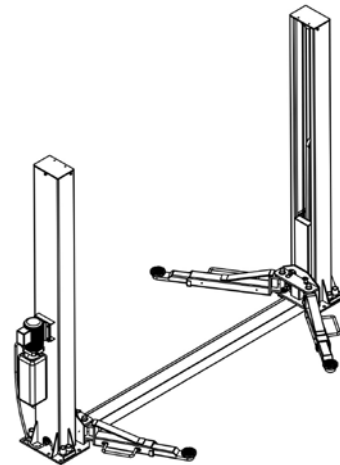

4.3.3 Operational and Wear Checks

4.3.3.1 Rubber Pads of Disk Adapters

1. Weekly check the rubber pads for wear.
2. Replace them as required.

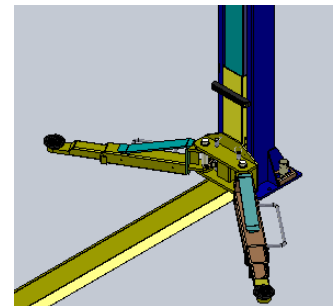

4.3.3.2 Arm Restraints

1. Weekly check the arm restraints for secure engagement.

4.3.4 Lift Stability

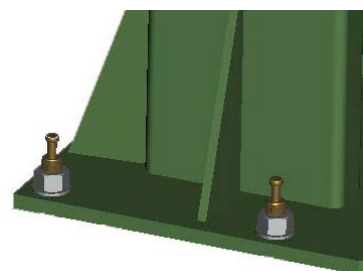
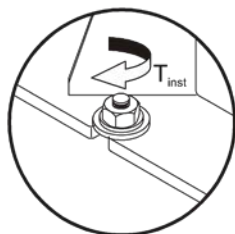

1. Every six months check the nuts of all anchor bolts for correct installation torque T_{inst} .
2. Retighten them as required.

	Installation Torque T_{inst}
QJY4.0-D	80 Nm

4.4 Cleaning



**Do not use high pressure / steam jet cleaners or caustic cleaning agents.
Risk of damage!**

- 1 Periodically wash off aggressive substances and treat the lift with oil or wax spray.
- 2 Repair damage to the paintwork immediately to prevent corrosion. The RAL number is available through the manufacturer.

4.5 Troubleshooting

Trouble	Diagnosis	Remedy
Lift does not respond.	The power off.	Plug in the power plug
	Mains fuse defective.	Replace mains fuse.
Motor starts up, pressure build-up insufficient to raise load.	Lowering screw open.	Close lowering screw.
	Lowering valve permanently open.	Contact service.
	Hydraulic system leakage.	Remove leakage.
	Low fluid level.	Check fluid level, add fluid as required.
	Load on lift too heavy.	Reduce load, observe rated load capacity.
Level difference between carriages too big.	Equalizing cables maladjusted.	Contact service.
Lift cannot be lowered.	Latch release defective.	Contact service.

4.6 Disposal

For disposal at end of working life, drain hydraulic fluid and dispose of fluid and other components through the normal industrial scrap route. No hazardous materials are used.

4.7 Installation

4.7.1 Space required

The lift must be installed on a level concrete floor, having minimum thickness of 30cm and an extension of at least 1.5m from anchoring points.

The lift installation concrete surface must be perfectly smooth.

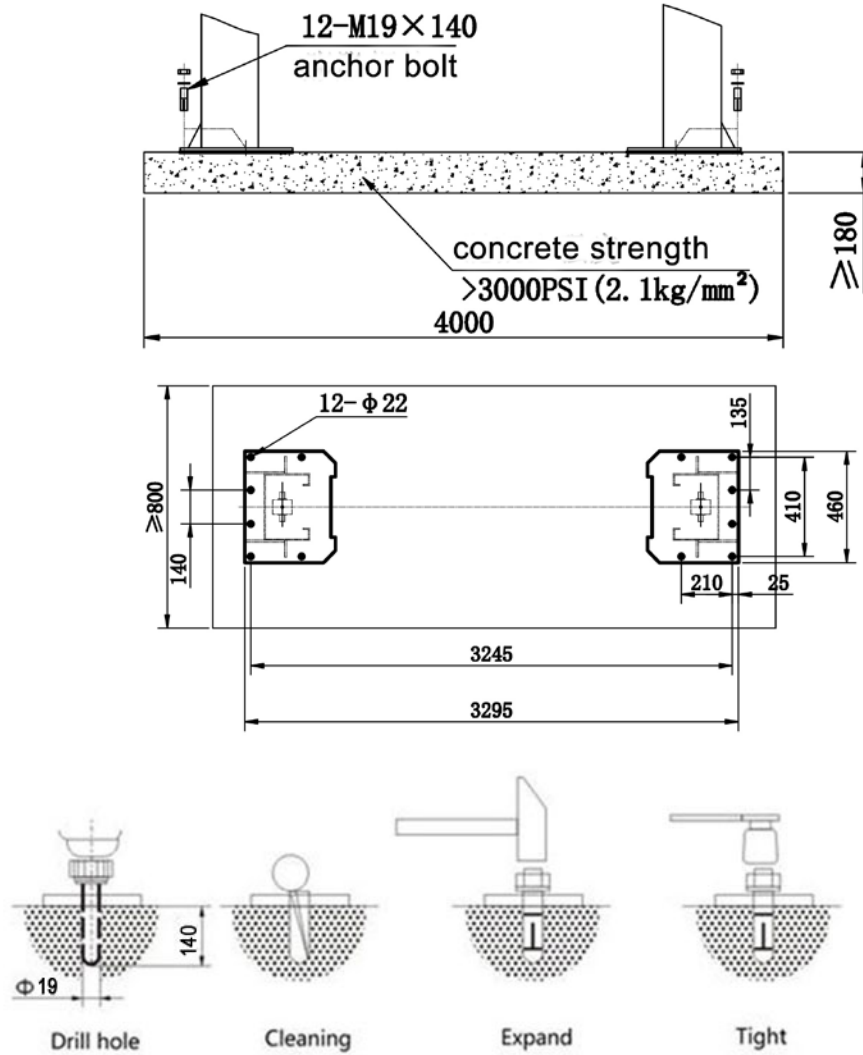

4.7.2 INSTALLATION

STEP ONE: (determine location and marks with chalk on the floor.)

1. Determine which side is the approach side and on which side the power unit to be mounted.
2. Once the location is selected, use a chalk line to layout a grid for the post locations and make an outline of the posts on the floor at each location.
3. Before proceeding, double check measurements and make certain that the bases of each column are square and aligned with the chalk line.

STEP TWO: (Mounting two columns)

1. Drill each anchor hole in the concrete using a rotary hammer drill. To assure full holding power, do not ream the hole or allow drill to wobble.
2. After drilling, remove dust thoroughly from each hole and make certain that the column remains aligned with the chalk line during this process.

3. If shimming is required, insert the shims as necessary under the base plate so that when the anchor bolts are tightened, the columns will be plumb.
4. With the shims and anchor bolts in place, tighten by securing the nut to the base then turning 2 -3 full turns clockwise. DO NOT use an impact wrench for this procedure.
5. Position the other column at the designated chalk locations and secure to the floor following the same procedures as outlined in step 1, 2, 3, 4.

STEP THREE: (Routing the Equalizer steel cables)

1. Raise and lock each carriage approximately 800mm high above the ground.
2. Make sure that the safety locks on each column are fully engaged before attempting to route equalizer steel cables.
Carriages must be equal height from the floor before proceeding.
3. With the carriages in equal position from the floor, route the equalizer cables as shown below.
4. After the equalizer cables have been routed, adjust each cable so that they are equal tension.



NOTE: The equalizer steel cables should be checked weekly for equal tension. Failure to do this will cause uneven lifting. The cables should always be adjusted so that they are equal tension when resting on the safety locks.

STEP FOUR: (Mounting the power unit.)

Attach the power unit to the POWERSIDE COLUMN with tools and parts. Fill the oil tank with hydraulic oil.



**Make sure the funnel used to fill the power unit is clean
In summer and winter you should change the oil**

STEP FIVE: (Installing Hydraulic Lines.)

1. Install the hydraulic lines as shown below, paying careful attention to keep the hoses clean and free of debris

Equalizer cables

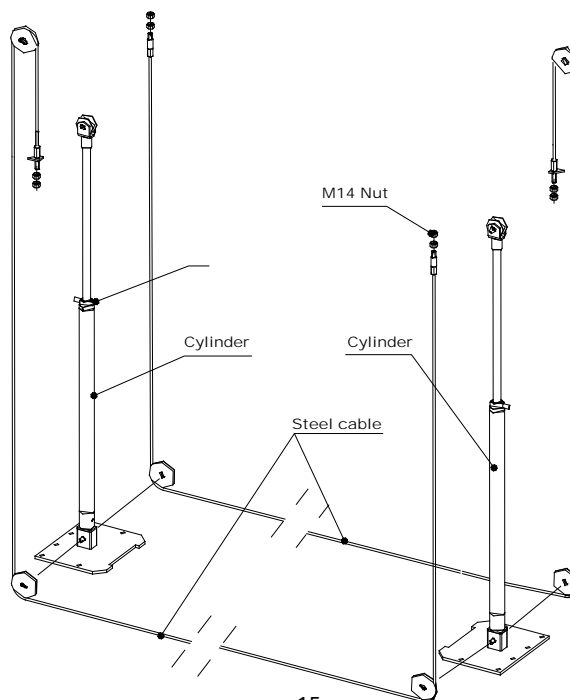

5. Hydraulic Drawing

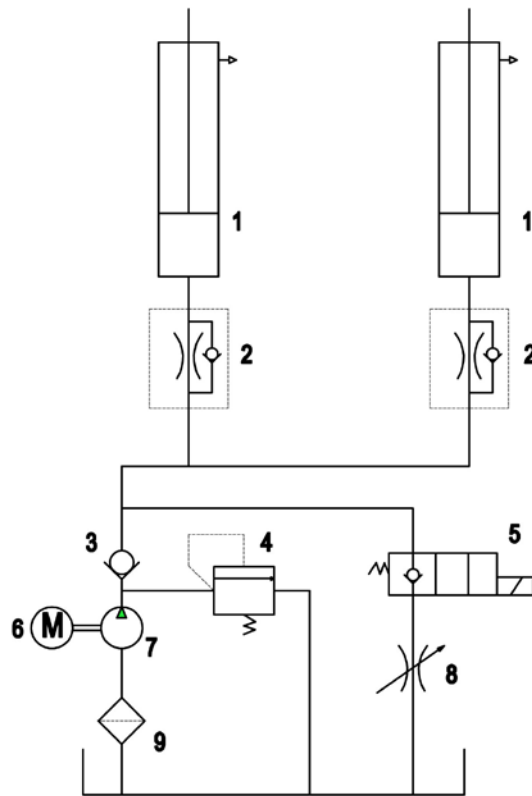

No.	Name	No.	Name	No.	Name
1	cylinder	4	overflow valve	7	gear pump
2	one-way throttle valve	5	unloading valve	8	adjustable throttle valve
3	one-way valve	6	electric motor	9	Filter

6. Exploded Drawing

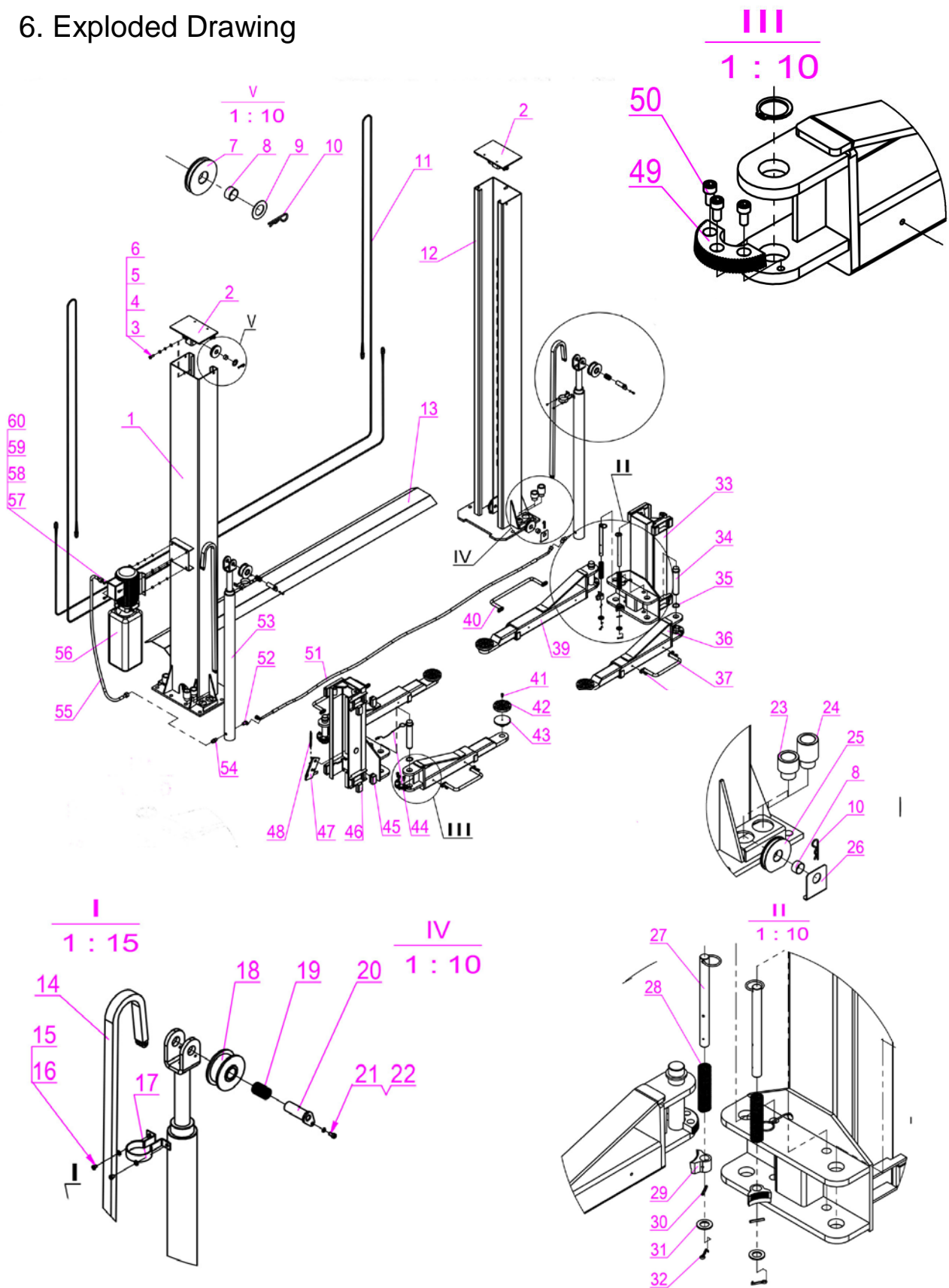

Spare parts list

No.	Name	Qty	No.	Name	Qty
1	Main column assembly	1	32	cotter	4
2	Top hat assembly	2	33	Carriage assembly	2
3	M10*35 bolt	6	34	Arm pin	4
4	D10 washer	6	35	D38 spring washer	4
5	D10 spring washer	6	36	Short arm assembly	2
6	M10 nut	6	37	Short arm protector	2
7	Cable pulley	2	38	M8*12 bolt	8
8	Oiless bearing	6	39	Long arm assembly	2
9	Cable pulley check ring	2	40	Long arm protector	2
10	B clip	4	41	M6*16 bolt	4
11	L=8460mm steel cable	2	42	Rubber pad	4
12	Sub column assembly	1	43	Pad weldment	4
13	Cover plate	1	44	Release cable	2
14	chain	1	45	Nylon block A	8
15	M6*8 screw	4	46	Nylon block B	8
16	D6 washer	4	47	Lock assembly	2
17	Cylinder fixing socket	2	48	spring	2
18	Chain pulley	2	49	Gear	4
19	Oiless bearing	2	50	M10*20 bolt	12
20	Yoke assbemly	2	51	L=2825mm hydraulic hose	1
21	D6 spring washer	2	52	fitting	2
22	M6*12 bolt	2	53	Double hole cylinder	2
23	1.5" adaptor	4	54	fitting	1
24	3" adaptor	4	55	L=1150mm hydraulic hose	1
25	lower pulley	4	56	Power unit	1
26	Cable protecting board	4	57	M8*25 bolt	6
27	Gear rod	4	58	D8 flat washer	6
28	Gear spring	4	59	D8 spring washer	6
29	gear	4	60	M8 nut	6
30	Round pin	4	61		
31	D22 washer	4	62		